

:: TABLE OF CONTENTS ::

- 1. Sensor Specifications
 - 1.1 Lifetime
 - 1.2 Basic operation conditions
 - 1.3 Basic storage conditions
 - 1.4 Final testing procedures prior to shipment

- 2. General Information
 - 2.1 Principle of operation
 - 2.2 Sensor handling
 - 2.3 Technical drawing & mechanical configuration
 - 2.4 Packaging, Labeling
 - 2.5 Intrinsic safety approvals
 - 2.6 How to dispose cells

- 3. Sensor Characteristics
 - 3.1 Signal Output
 - 3.2 Cross effects of ambient gases
 - 3.3 Temperature dependency
 - 3.4 Absolute pressure and flow effects
 - 3.5 Influence of humidity
 - 3.6 Response Time
 - 3.7 Drift considerations and long term stability
 - 3.8 Zero offset
 - 3.9 Installation, mounting position
 - 3.10 Shocks, Motion, Position Stability
 - 3.11 Noise, EMC
 - 3.12 Interfacing, Electrical, Mechanical

- 4. Customised Versions
 - 4.1 OEM Modifications
 - 4.2 Product Identification

:: 1. SENSOR SPECIFICATIONS ::

1.1 Lifetime

Since the I-01 oxygen sensor is a galvanic cell, life is calculated based on the theoretical consumption of cell components (i.e. lead anode & electrolyte). Life is specified as oxygen-volume percent-hours:

$$\begin{array}{c} [\text{Oxygen concentration (Vol.\%)}] \\ \times \\ [\text{Exposure time (hours)}], \end{array}$$

and is considered "nominal lifetime".

For the I-01, nominal lifetime is estimated to be approximately 1,200,000 oxygen Vol.% hours. This indicates an expected lifetime of over 6 years in ambient air (20.9%).

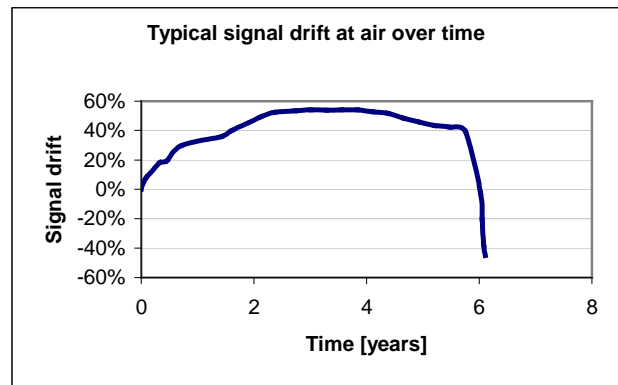

Figure 1: typical lifetime curve of I-01

The end of lifetime is defined as the time when the sensor has dropped on more than 30% within 6 weeks period. Figure C depicts a typical lifetime output curve of an I-01 randomly taken out of a production lot.

It is, however, important to note that several factors effect the actual lifetime of a sensor. These factors include storage temperature, operating temperature / pressure, humidity and exposure to chemicals.

1.2 Basic operation conditions

The I-01 is designed as a disposable unit and when the lead anode is consumed due to the sensing of oxygen, the cell is simply discarded. The cell is, therefore, maintenance free requiring no replacement of membranes or electrolyte and no cleaning of electrodes.

It is important to note that the I-01's output signal depends on some physical conditions mainly pressure, temperature and humidity.

Absolute and partial pressure

Although most of the analysis techniques are set up to readout the concentration of oxygen in percentage units, the I-01 cell are actually sensitive to the partial pressure of oxygen in the sample gas mixture. Readouts in volume percentages are only correct when the total pressure of the gas being analysed does not change and the instrument has been calibrated at that pressure.

The flux of oxygen to the working electrode is dependent on the partial pressure gradient of oxygen across the barrier. This means that the output signal from the cell is proportional to the partial pressure of oxygen in the gas mixture. Any changes in atmospheric pressure will therefore result in an equivalent change in the output current of the cell. It is important that this characteristic is considered when designing instruments to ensure that back pressure is not applied to the cell when using pumped gas feeds.

Temperature

In order to obtain accurate readouts that vary only with changes in oxygen concentration, temperature must be taken into account. The rate at which oxygen molecules interact with the cathode is governed by diffusion through the sensing membrane and the film of electrolyte between the membrane and cathode. Since all diffusion processes are temperature sensitive, a varying electric output can be expected with changes of temperature (at a constant level of oxygen).

The I-01 cell itself has a positive temperature coefficient and thus a negative temperature coefficient thermistor is used to compensate for this effect such that reduces the output error to $\pm 3\%$ in a temperature range from 10°C to 40°C. Figure 4 shows the manner in which this temperature compensation is effected.

Humidity

Dalton's Law of Partial Pressures states that the total pressure exerted by a mixture of gases is the same as the sum of the individual pressures exerted by the constituent gases. Or, stated another way, in a mixture of gases, every gas exerts the same pressure as if it would be alone confined in the same volume.

Humidity, or in other words gaseous water, is just another constituent and its amount of volume (partial pressure of H₂O) contributes to the total pressure. Thus, the more humidity is in place at the same absolute pressure the less the partial pressure of oxygen will be. The humidity correction factor is given in the specification sheet of the I-01.

1.3 Basic storage conditions

Since the I-01 is a designated long-life cell it is best to leave it in the original package (tin can). Each individual unit comes in a closed container to protect the cell against dust and unintentional damage. The containers can also be stacked for space-saving requirements.

Ensuring maximum shelf life stocking temperature, pressure and humidity should not be outside the condition range given in the current specification sheet.

It is not advisable to keep the sensor under refrigerated condition if an immediate use is required. Refrigerated cells require several hours to reach equilibrium to ambient air temperature prior to replacement and subsequent initial calibration procedure.

1.4 Final testing procedures prior to shipment

Quality assurance

IT Dr. Gambert is committed to provide customers full satisfaction guarantee. Sensors are supplied with a customised test report. Every single sensor (100%) has to pass the company's final inspection routine according to the ISO 13485 standard. IT Dr. Gambert computerised database records all comprehensive information for each individual sensor. This can be made available to the customer.

Final Testing procedure

Each of the I-01 cells are tested and accepted according to the following test criteria shown :

Testing subject	Testing calculation/procedure	Test criteria/acceptance
Output signal	Measurement of output voltage at ambient air, 1013mBar, 25°C and 50% r.H.	$V_{out\ min.} = 10.5\ mV$, $V_{out\ max.} = 13.5\ mV$
Response time	T-90 time measured from ambient air down to baseline	$T_{90} < 5\ sec$
Linearity error	Relative Linearity from 2 to 35 Vol.% is equal to: $(V_{actual} / V_{nominal} - 1) \times 100\ [\%]$	Lin. Error = $\pm 0.5\ \%$ relative
Form factor	Outer dimensions, Mx16 thread, Molex connector against drawing and specification.	Max. Tolerances = 0.15mm, Polarity check
Good shape	Visual inspection	No fins, burrs, staining on housing material, thread, edges
Labelling, Identification	Check of part- and serial number, warning hints	All items must meet documentation

.: 2. GENERAL INFORMATION .:

2.1 Principle of operation

The model I-01 oxygen sensor can be considered as a lead-oxygen battery, consisting of a lead anode, a coated cathode (silver), and a weak acid electrolyte. Unlike a polarographic cell this galvanic cell type does neither require any external power supply nor expensive electronic for the signal evaluation.

A non-porous PTFE film is bonded to the silver electrode. Oxygen permeating the film is electrochemically reduced at the sensing surface of the cathode. Once the Anode is electrically connected with a circuit that contains an incorporated resistor to the cathode, the current generated is directly proportional to the partial pressure of oxygen at the sensing surface of the cell. This circuit compensates temperature effects and provides a millivolt output signal.

This temperature circuit effectively compensates the output signal between 10°C to 40°C with a signal error of $\pm 3\%$ and from 0°C to 50°C with an error of $\pm 6\%$. For minimum and maximum operating temperatures please refer to the current specification.

Since the I-01 sensor uses an acid electrolyte, it is unaffected by the presence of background gases such as CO₂.

2.2 Sensor handling

The I-01 is designed as a multipurpose sensor for no specific environment. Excellent performance can be attained by following a few simple guidelines:

- Do not connect any external bias voltages to the sensor. In particular, do not design electric circuitry which would inherently charge the sensor.
- Input amplifiers of any associated instrumentation should be designed so that the minimum operating load on the sensor is 1M Ω .
- Take precautions to prevent any dust particles and/or condensation on the sensing surface of the cell. If a cell is contaminated with liquids that are erroneously introduced into the sampling system of the analyser, the cell can be removed from its holder and cleaned with water and dried with lint-free wipes. This procedure will in no way impair future performance of the cell. It is important to remove any liquids that would condense or otherwise find themselves on the sensing membrane of the cell. Films of liquid will impair the normal diffusion path and result in erroneously low readings.
- Do not expose the sensor to environments and/or gas sample streams exceeding those listed under "Operating temperature" in the specification sheet.
- The sensor's built-in temperature compensation is designed to work best when sensor and environment are in temperature equilibrium. If the sensor body is cooler or warmer than the environment it may affect the resulting output signals.
- For optimal performance and life characteristics, it is recommended to mount the sensing surface of the sensor pointing down or in a horizontal position. Do not install the sensor with its sensing surface facing upward. This guideline should also be noted for storage of the sensor.
- Never stress the I-01 with a differential pressure of more than 300 mBar. Doing so will destroy the cell.
- Do not subject the sensor to excessive shocks or vibrations.
- Do not submerge the sensor partly or completely into liquids.
- Do not open any part of the sensor body.

2.3 Technical drawing & mechanical configuration

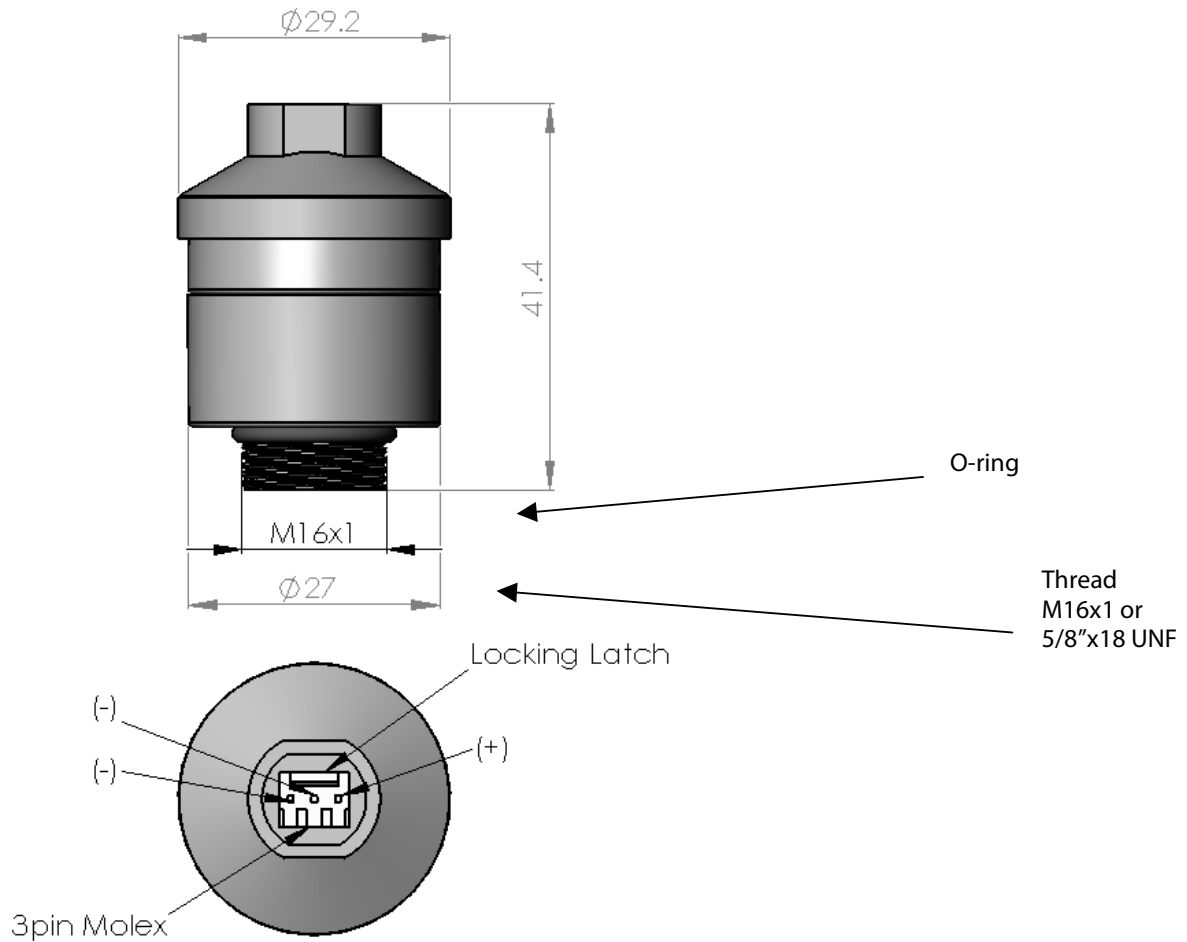

Figure 2: Outer dimension and electric terminal

2.4 Packaging, Labeling

All I-01 cells are originally packaged in a non-hermetically sealed container (tin-can). There is a small pin-hole on top of the tin-can guarantying transmittance of small amounts of oxygen. Negligible amounts of moisture can reach the inside of the tin-can. The cell can thus be stored for periods in excess of six months and still provide 90 – 95% of expected life when finally placed in use. Furthermore, the cell will give accurate, reliable readings at all times from the very first moment and beyond.

It is not suggested, however, that cells be stock piled or stored any longer than logistics necessitate.

IT Dr. Gambert maintains a stock of all cells that can be normally shipped the same week orders are received.

The label graphic of each cell is divided into three fields, the first left field contains any information of organisation distributing the cell. The second, middle part is the identification field providing information such as type of sensor, part number P/N and serial number S/N. The third right field contains warning notices and a bar-code.

2.5 Intrinsic safety approvals

As per the general requirement of EN 50014 in section 1 clause 1.3 a device as defined may not exceed at any time one of the physical values 1.2 V; 0.1 A; 20 μ J or 25 mW.

Hence, there are 3 cases to consider:

Case 1 "Open circuit"

A batch of fresh I-01 cells were tested to work on a load of 1 GOhm at 100Vol% O₂; 1013mBar, 35°C.
The max. output voltage did not exceed 120 mV.

Case 2 "Short circuit"

A batch of fresh I-01 cells were tested to work on a load of 10 Ohm at 100Vol% O₂; 1013mBar, 35°C. The short circuit has been performed and the transient function recorded.

At no time the peak current of the core cells exceeded values of: 100 μ A
The maximum output power generated was: 0.1 μ W.

Case 3 "Operating condition"

A batch of fresh I-01 cells were tested to work on a load of 1 MOhm at 100Vol% O₂; 1013mBar, 35°C.

At no time the maximum output power exceeded values of: 0.09 μ W.

2.6 How to dispose cells

At the end of the I-01's lifetime the sensor should not be disposed of in normal public waste as it contains some lead and acid electrolyte. Please contact your local authorities for environmental legislation to relevant local waste disposal.

:: 3. SENSOR CHARACTERISTICS ::

3.1 Signal Output

The rate of gas diffusion (rate of oxygen molecules) permeating a membrane type sensor is directly proportional to the partial pressure of oxygen on both sides of the membrane according to Fick's law. At the cathode side of the membrane oxygen will be reduced and therefore the partial pressure drops down to almost zero. Hence a pressure difference occurs between both sides of the membrane which is then equal to the oxygen partial pressure.

The I-01 sensor is designed to measure oxygen in the range from 0.5 Vol.% to 35 Vol.%, The sensor output is linear with respect to the partial pressure of oxygen. The sensor is compensated for the effect of temperature in the range from 10°C to 40°C with a minimum error. Each new sensor has a unique signal output which will fall within the area defined between "Max" and "Min" curves as depicted in Figure 3. The full scale (35 Vol.%) linearity error of the I-01 is ± 0.5 % relative at constant temperature and pressure.

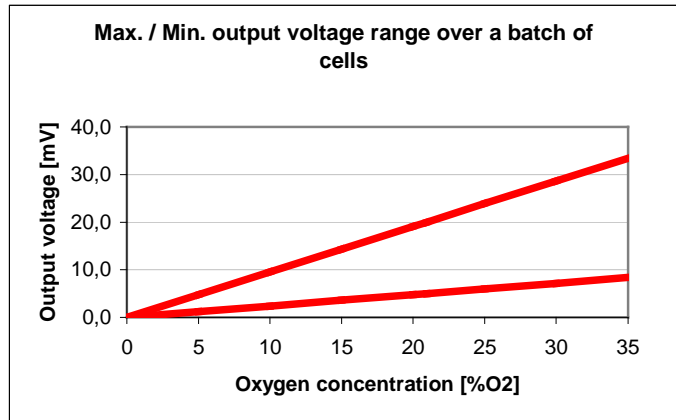

3.2 Cross effects of ambient gases

The I-01 is filled with a weak acid electrolyte giving it an exceptional life characteristic. In addition, this specially formulated solution of acetic acid electrolyte is virtually unaffected by the presence of background gases such as CO₂, SO₂, and NO_x. Furthermore, several other gases including refrigerants and hydrocarbons show only little effect on the cell. However, since the electrolyte is acidic, the I-01 sensor shows some sensitivity to high concentrations of caustic vapors as shown in table 2.

Level of effect	Type of gas
No effect	CO ₂ , CO, H ₂ S, N ₂ , Ar, H ₂ , CH ₄ , Propane
Minor effect	Cl ₂ , CFC's, SO ₂ , NH ₃ , NO, NO ₂
Moderate effect	Isopropyl alcohol, Hexane, CCl ₄
Severe effect in high concentrations	O ₃ , Acetone, MEK

Table 1: Cross sensitivity

- Minor effect:* Output signal will show some interference, sensor will not be damaged.
- Severe effect:* No signal interference, but sensor will be damaged if exposed over longer period of time.

3.3 Temperature dependency

The I-01 has a temperature compensating network incorporated in the sensor body. This thermistor network corrects and stabilises the output signal for the effect of temperature in the range of 10°C to 40°C with a maximum error of $\pm 3\%$ absolute and between 0°C to 50°C an error of $\pm 6\%$ can occur. The temperature dependency with built-in compensation network is shown in figure 4. This curve has been taken by static measurement of ambient temperature. As temperature rises the output signal increases and vice versa.

The I-01 sensor may show some transient characteristics if the ambient temperature changes very rapidly or in large intervals. This dynamic characteristic is caused by the difference in response speed to temperature changes between the sensor current and the resistance of the thermistor. As the thermal mass of the sensor typically slows down any transient temperature effects, however, signal drift can occur due to the built-in compensation network.

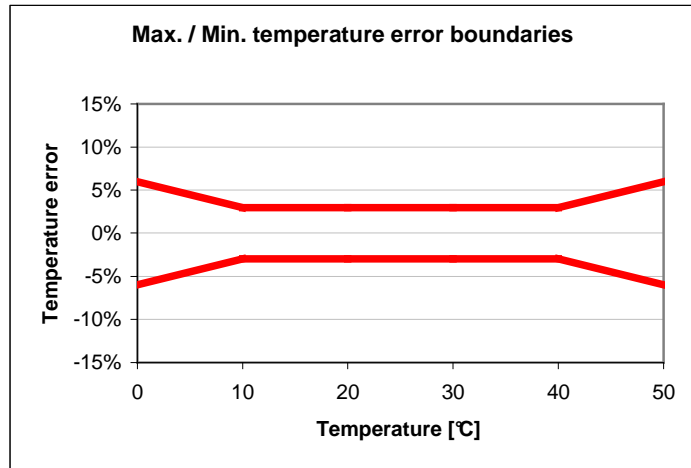

Figure 4: min.-max. temperature error limits

3.4 Absolute pressure and flow effects

In addition to the partial pressure dependency on oxygen the I-01 responds to changes of absolute barometric pressure that it is exposed to. The relationship of the output signal to changes in the absolute pressure may be expressed by the equation:

$$V_{\text{output}} = V_{1013\text{mBar}} \times P / 1013\text{mBar}$$

where: V_{output} = output voltage
 $V_{1013\text{mBar}}$ = output voltage at 1013mBar
 P = barometric pressure

The I-01 sensor is suitable to work in an absolute pressure range from 750 mBar to up to 1250 mBar.

The sensor output signal is not directly affected by gas flow, however a minimum flow of 20 ml per minute should be maintained to assure proper exchange at the sensing area of I-01. The maximum gas flow depends on the sampling system itself.

Some hints to sampling system design:

- The "driving source" of pressure changes (usually a pump), if possible, should work in a "suction-mode." Source to be installed down-stream of the sensor's sensing area.
- In order to achieve maximum response time the dead space in the sampling system should be reduced to a minimum.
- Gas flow should contact the sensors sensing surface area at a 45° angle in order to obtain best response time.
- All sampling systems produce more or less positive and negative transient pressure/flow effects and some may resonate. Try to minimize such effects on the output signal.
- Dampen restrictors, like valves or flow modulators, located before and after the sensor's sensing area will assist to obtain a smooth and even flow.
- For optimal results the gas temperature should be the same as the sensor's ambient temperature. Try to avoid sudden changes or gas temperature fluctuations.

3.5 Influence of humidity

Humidity can be considered as water in gaseous form. Humidity does not permeate the membrane into the cell and thus, humidity has no influence on the cell. However, the output voltage drops in the presence of humidity simply by the displacement of oxygen.

Figure 5 shows that the change of oxygen concentration is directly related to the dilution effect of water vapor.

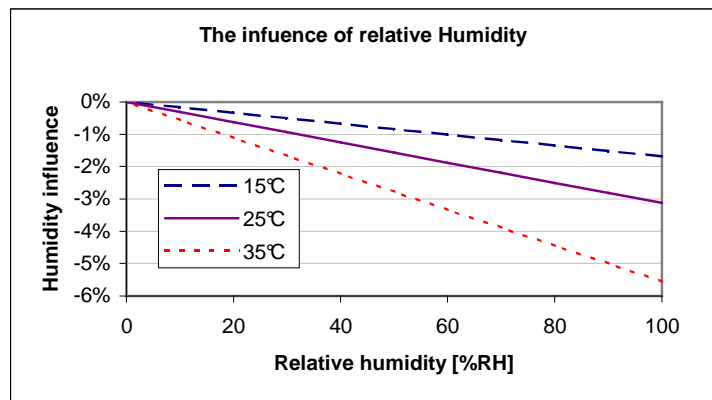

Figure 5: The influence of humidity at certain temperatures

3.6 Response Time

When not considering gas flow and sampling system design, the response time of the I-01 depends predominantly on the diffusion of O₂-molecules through the membrane. Travelling time of the cations/anions through the electrolyte plays only a minor role. A step change of oxygen from baseline to 90 % of the final value will be in less than 5 seconds. The same is valid when inversely arranged. The response time is nearly independent from the step in oxygen concentration.

3.7 Drift considerations and long term stability

Under normal operating conditions, I-01 sensors exhibit less than 1% drift (full scale) over an 8 hour operation period at constant temperature and pressure.

However, there are various factors that determine long term stability and drift of oxygen sensors.

These major factors are directly related to the application and include:

- Operating temperature (3.3)
- Sample pressure (3.4)
- Shock and vibration
- Chemical exposure (3.2)

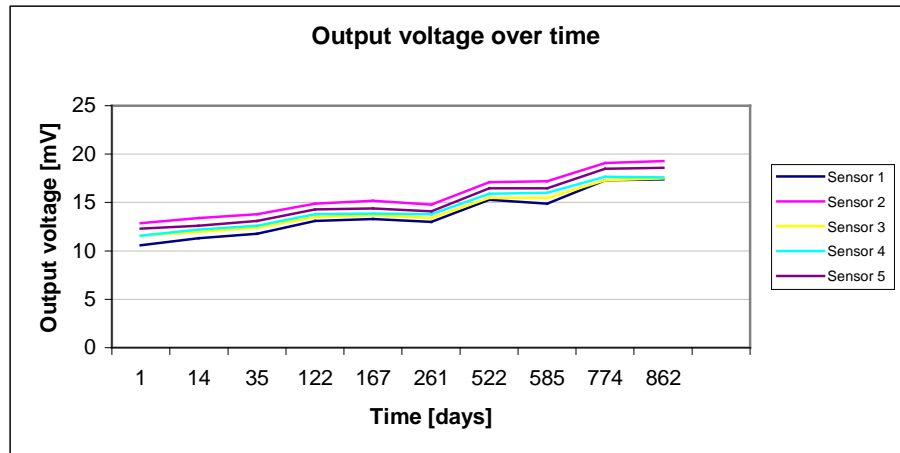

Figure 6: Initial long term drift

The I-01 is warranted for one year after the date of shipment. When a sensor is used in normal air according to its intended use and without any incidental misuse, the sensor will have good performance in long term characteristics as illustrated in figure 6.

3.8 Zero offset

The I-01 sensor has a PA12 plastic housing. On a very small scale some oxygen from the surrounding atmosphere can permeate the housing wall into the sensor resulting in a small baseline voltage. However, upon completion of the sensor manufacturing, air equilibrium is quickly reached to the surrounding environment.

When a gas stream consisting of 100Vol.% nitrogen (N_2) is exposed to the sensing area of the I-01, the baseline voltage (zero voltage) will be less than 240 μV which is equal to 0.5 Vol. % oxygen.

3.9 Installation, mounting position

The I-01 features a M16x1 thread and an O-ring to seal the gas intake area from the ambient environment as well as provides sufficient securing and thus eliminates the need for additional clamps or other supporting systems. Optimal mounting position of the I-01 is when the gas sensing area faces downward. A horizontal position is acceptable. It is not recommended to use the I-01 with the gas sensing area facing upward.

Since temperature has an influence on the output signal it is not advisable to place any heat or vibration sources (i.e. electric-pumps or valves, coolers, etc.) in close proximity to the cell.

Avoid proximity of the cell to any EMC radiating units as those emit frequencies which might interfere with the sensor's electrical connection and connecting cable. And minimise the length of the connecting cable between the sensor to the input amplifier. When the sensor is placed externally from the analyser the cable length should not exceed 1 meter.

3.10 Shocks, Motion, Position Stability

Mechanical shock and vibration may affect the inner structure of the sensor and so should be avoided. Temporary fluctuations in the sensor's output signal may result due to shock and vibration. Depending on the severity of vibration or shock imparted on the I-01 oxygen sensor, the signal may recover to its original state after the sensor is kept motionless in normal operating temperature. If the mechanical shock or vibration is great, an irreversible change in the output signal may occur due to structural damage within the sensor.

Shock absorbing measures should be used to protect the sensor during transportation or when used for applications in where shock or vibration is likely to occur. Although the sensor is a robust package, it should not be exposed to shock greater than 2 G force.

Position Stability:

The sensor should be mounted in a vertical position with the sensing face pointed down. In portable instruments, the sensor may be mounted with the sensing face pointing sideways. The purpose of these orientations is to facilitate keeping the sensing portions of the cell immersed in the electrolyte and to prevent the cathode/ membrane from drying out. If this were to occur, the sensor's output signal would fluctuate.

3.11 Noise, EMC

Emitting noise, radiation:

Galvanic oxygen cells generally do neither emit nor contribute much noise to the system. In an EMC protected cage and at normal operating conditions (20°C, 1013mbar, 60% r.H., 10 MOhm load) max. noise being measured is not more than 5 μ V. Hence the signal-to-noise-ratio (S/N) is not more than 2000 : 1 or in other words 0.02 %. This is more than 5 times less that of the required resolution for typical oxygen analysers.

No electromagnetic radiation will be detected from an I-01 since the power from the sensor DC-current does not exceed 0.1 μ W.

Receiving noise, radiation

Galvanic cells, like the I-01 can be considered as a large capacitance of about 10 μ F. This combined with the built-in resistor network of about 7.5 kOhm results in a low-pass filter with a decay time (τ) of 75 msec. Such a slow decay time and its resulting cut-off frequency (approx. 13 Hz) is negligible for susceptibility of the sensor set-up.

3.12 Interfacing, Electrical, Mechanical

Electrical:

A 3-pin Molex® plug MXI-11 (6471) must be used for this socket. With reference to figure 2 only the right-side pin of the I-01's terminal delivers the positive signal output voltage against minus. For optimal performance the first stage amplifier input impedance (R_i) shown in figure 7 of the measurement device should be greater than 1M Ω . Never use a current-to-voltage converter as this circuits will disable the built-in temperature compensation.

The temperature compensation network, consisting of R_s , thermistor (ϑ), R_p , is incorporated in the cell and cannot be changed. The connecting cable length between the sensor and the measurement device must not exceed 1 meter.

Mechanical:

In most cases the I-01 is used in a diffusion mode, not attached to any sampling system. For such cases the cell should be fixed either around its body or by using the M16x1 thread.

When the cell is used with a sampling system the equipped M16x1 thread with the supplied O-ring is the required attachment method for a gas tight system. The I-01 thread can also be mated with a 5/8"x18 UNF inner thread. The sensor's total weight is approx. 25 grams and does not require additional fixturing to keep the cell mechanically stable in position. Never stress the I-01 with a differential pressure of more than 300 mBar. Doing so will destroy the cell.

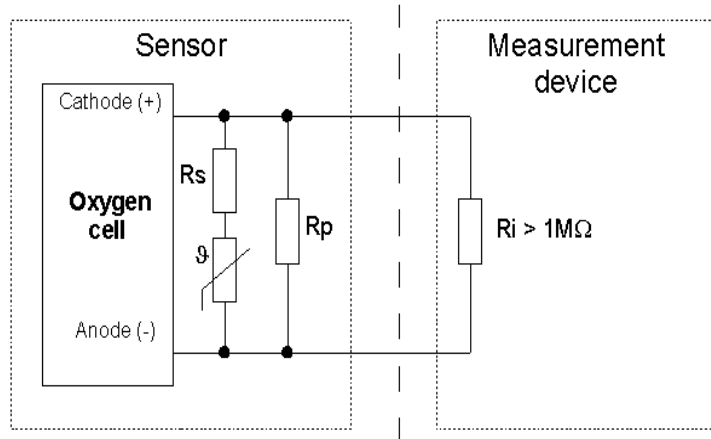

Figure 7: Schematic layout of I-01 interface

:: 4. CUSTOMISED VERSIONS ::

4.1 OEM Modifications

IT Dr. Gambert welcomes and encourages OEM's to discuss their special requirements. Our development department will be more than happy to provide support in order to determine the best fit for your application.

Please note, that the price of modified sensors will be higher than that of standard products. The amount of price increase will depend on the extent of the required design and committed quantities.

4.2 Product Identification

The I-01 is part of IT Dr. Gambert's industrial sensor line. The intended use is defined as "gas cell for measuring partial pressure of oxygen in the gas phase at certain temperature, humidity and pressure."

It is specified for the use of food packaging analysis, leakage test, combustion and fermentation process monitoring and emission.

When ordering this item use part number 480014.